

8' Multi-Purpose Easi-Frame Assembly Instructions

Using this frame with:

- An XL Joinery door pair (using hinges) with either fixed or hinged Easi-Frame side panels or Demi Panels on either side
- Easi-Frame Panels used as a Bi-fold with a fixed or hinged Easi-frame Panel or Demi-Panel on either side
- Easi-Frame Panels or Easi-frame Demi Panels as a walkthrough project

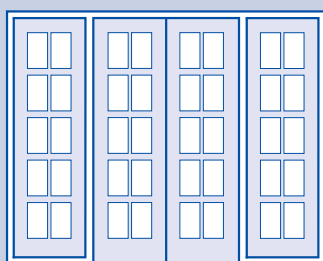

Hinged Door Pair with Panels

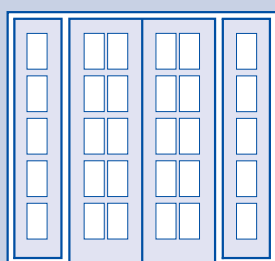

Hinged Door Pair with Demi Panels

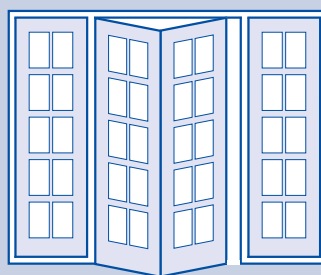

Easi-Frame Panels used as Bi-Folds with Panels

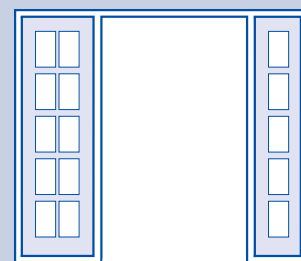

Panels or Demi Panels used as a walkthrough











Important - Read these instructions fully before starting your project.

Only when you fully understand the methods described here do we recommend you proceed.

If you have any doubts please contact our Technical Helpline on 07000 785571

Pack Contents:

Please check the contents of this pack against the following list:

	Head Lining	1	(22 x 135 x 2512mm)
	Vertical Lining	2	(22 x 135 x 2025mm)
	Door/Panel Stop	2	(2025mm)
		1	(1192mm)
	Lining Mullion	2	(44 x 135 x 2025mm)
	Panel Bead	8	(594mm)
		8	(2025mm)
	Panel Mullion	1	(1981mm) used when installing bi-folds only
	Lining Head Bead	1	(1192mm)
	Lining Head Bead	2	(594mm) used when installing bi-folds only
	Lining Head Infill	2	(13 x 27 x 638mm) used when installing bi-folds only
	Bottom Rail	4	(22 x 47 x 594mm) Used when installing fixed Side Panels only

If you are working on a Bi-Fold project you must also purchase an Easi-frame Bi-fold pack. This is available from the retailer where you purchased your Easi-frame Panel, Demi Panel or Frame

Fixings and door furniture are not supplied in this pack.

This Frame is NOT SUITABLE for the installation of 32" (2032 x 813mm) Doors

DEPENDENT ON YOUR PROJECT THE HEAD LINING WILL HAVE TO BE TRIMMED TO ACCOMMODATE THE DIFFERING WIDTHS OF THE DOOR PAIR, BI-FOLDS, PANELS OR DEMI PANELS

Whilst we take every care to ensure that the design of the Easi-frame system, the descriptions given in catalogues and on labels and the methods of construction detailed here are accurate, we reserve the right to change the specification at any time.

The information given here may not be re-produced or transmitted in any form without the express permission of XL Joinery. Permission can be requested from the XL Joinery Marketing Department on 01924 350501

© XL Joinery Ltd 2004

Project	External Lining size (Height measured from existing floor covering)	
	Height (mm)	Width (mm)
XL Pine Pair and two Easi-frame Panels either fixed or hinged on either side	2007	2494
Easi-frame lining used with two Easi-frame panels or Demi Panels as a walkthrough	2024	2512*
Easi-frame Panels used as a Bi-fold and two Easi-frame Panels either fixed or hinged on either side	2024	2512
Easi-Frame panels used as a bi-fold and two Easi-Frame Demi panels either fixed or hinged either side	2024	1904
XL Pine Pairs and two Easi-frame Demi Panels either fixed or hinged	2007	1896

Use these dimensions to create the correct opening size or prepare the stud wall framework if building a room divider or bedroom wardrobe. Internal Lining dimensions vary dependent on your project - refer to the diagrams for each project to calculate the required dimensions

*Maximum Dimension

Important notes to consider before assembly starts:

1. The lining verticals are supplied slightly longer than required, and will need cutting to size, depending whether or not there is an existing floor covering that needs taking into consideration. Take careful measurements especially if the bottom of the lining verticals and mullion are to sit below any existing floor covering. It is very important that you establish the internal lining dimensions. Internal Lining dimensions vary dependent on your project - refer to the diagrams for each project to calculate the required dimensions. Working to these dimensions will ensure that doors open freely over the floor covering without the need to reduce the height of the door pair; bi-folds; panels or demi panels
2. The depth of the door lining allows for a wall thickness of 135mm. If your wall dimensions are less than each of the three lining lengths will have to be reduced in width
3. If the opening is plasterboard faced. It will need to be lined with a timber sub frame onto which the lining will be fixed

Constructing the Lining

The instructions for constructing the lining are similar for all projects except for:

- g The various dimensions required dependent on your door; bi-fold; Panel and Demi panel configuration.
- g The direction the groove on the head lining should face. Detailed below are the standard instructions, the various diagrams will give you your lining measurements and the table opposite will show you which way the groove in the headlining should face.

How to start:

Check that you have the necessary components in your pack - see list on Page 2

Assemble the lining as in the appropriate diagram (see table opposite). The correct internal width dimensions must be achieved depending on the type of panels you are fitting.

The height dimension shown is from floor covering level to the underside of the head lining. Adjust this dimension if

the vertical lining or the mullion will sit below the surface of the floor covering.

Trim the two ends of the lining head to be flush with the verticals if necessary

Diagram and Headgroove Direction

Project	The Groove in the Head Lining Faces:	Diagram to refer to
XL Pine Pairs and two Easi-frame Panels either fixed or hinged on either side	UPWARDS	2
XL Pine Pairs and a two Demi Panels either fixed or hinged on either side	UPWARDS	4
Easi-frame Panels used as a Bi-fold and an two Easi-frame Panels either fixed or hinged on either side	DOWNWARDS	3
Easi-frame Panels used as a Bi-fold and an two Easi-frame Demi Panels either fixed or hinged on either side	DOWNWARDS	5
Easi-frame lining with either two Easi-frame Panels or Demi-panel used as a walkthrough	UPWARDS	6

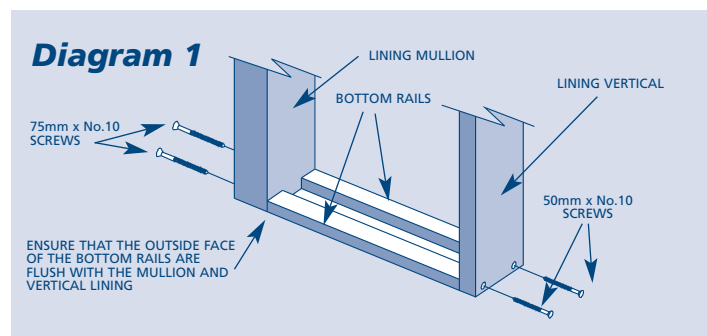

If you are framing the Panels in the fixed position, fit the bottom rails in between the lining vertical and mullions as in **Diagram 1** on page 2. Ensure that the outside face of the bottom Rails are flush with the Mullion and Vertical Lining

Pre-drill all screw fixing holes (Fixings not supplied)

Trim the two ends of the lining head to be flush with the verticals.

Continue the project by referring to the section on fitting the lining

Extra Information for using an Easi-Frame Lining with Panels or Demi Panels as a Walkthrough

Because the open space of the Walkthrough is not a set width - you must decide on the width of open area you require before constructing the lining. The maximum width you can have is:

Walkthrough	Maximum External Dimension	Panel width	Demi Panel Width	Lining Mullion Width	Maximum Opening Width
2 x Panels	2512mm	2 x 594mm	N/A	2 x 44mm	1236mm
1 x Panel + 1 x Demi Panel	2512mm	594mm	295mm	2 x 44mm	1535mm
2 x Demi Panels	2512mm	N/A	2 x 295mm	2 x 44mm	1834mm

Other combinations are possible leaving smaller openings: the above table should be used to calculate maximum internal dimensions.

How to construct your lining's - refer to diagram that applies to your project

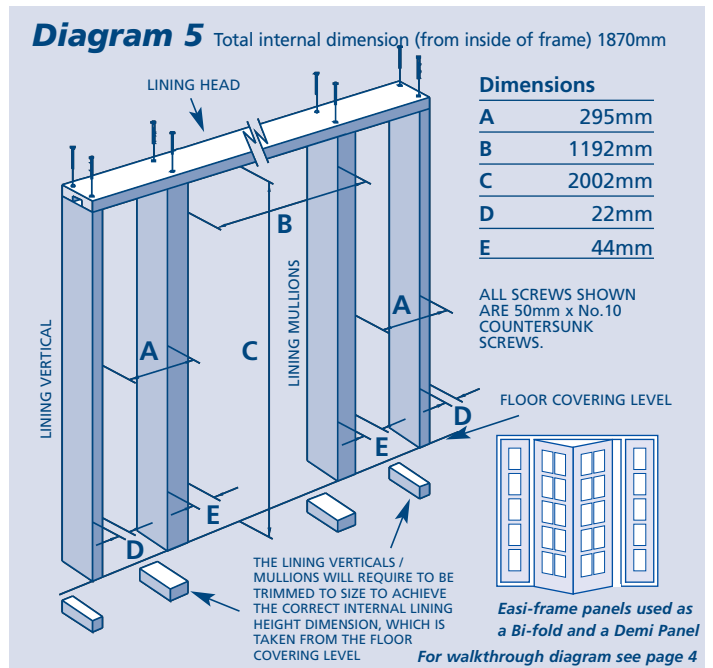
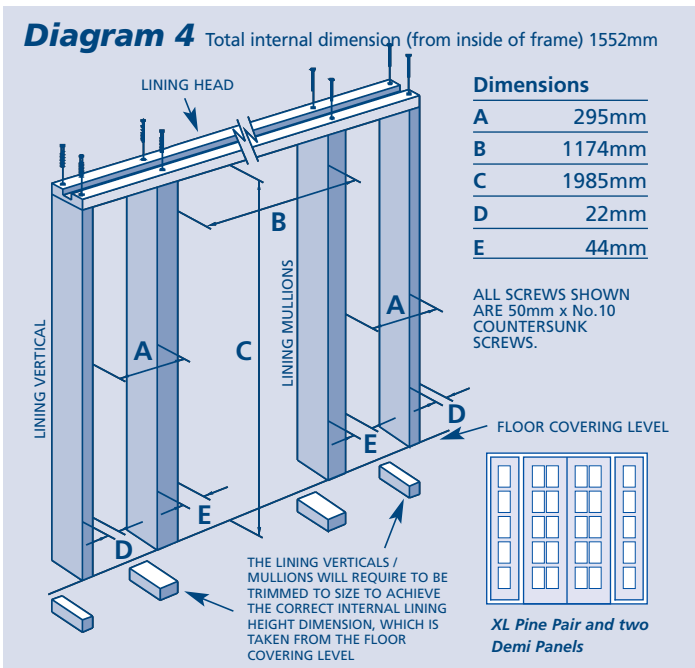
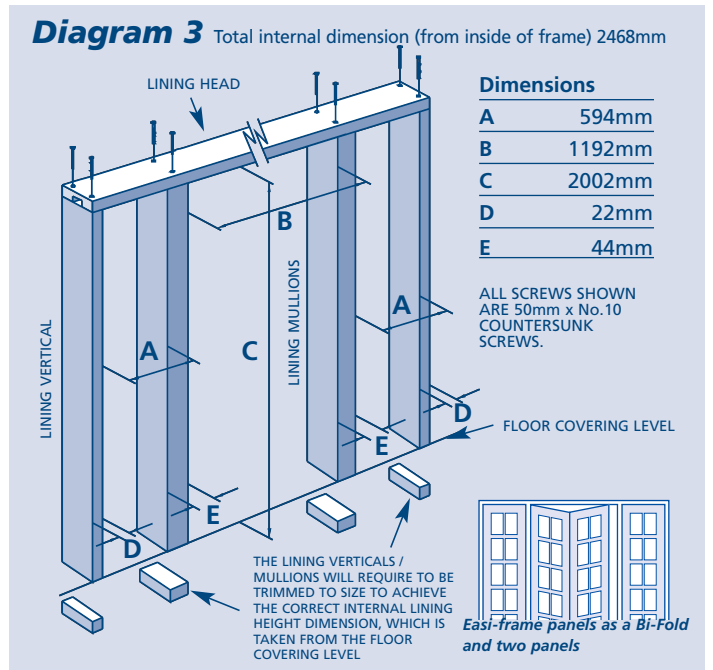
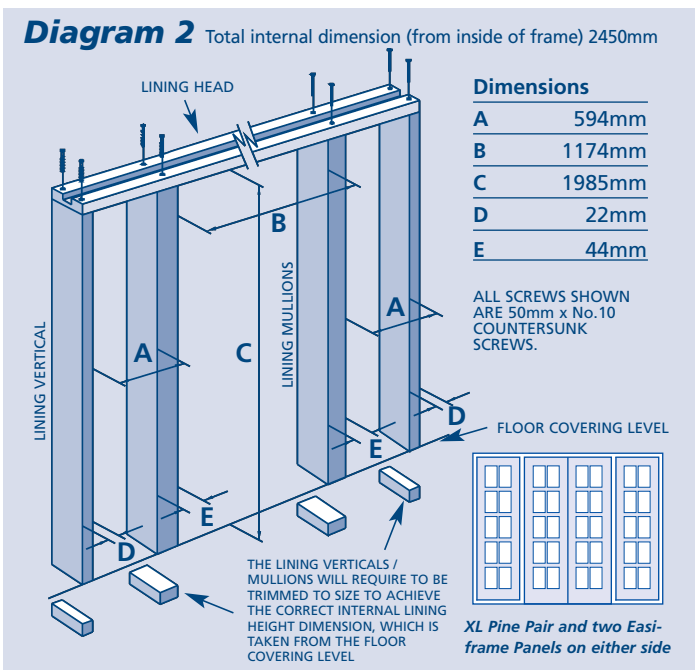
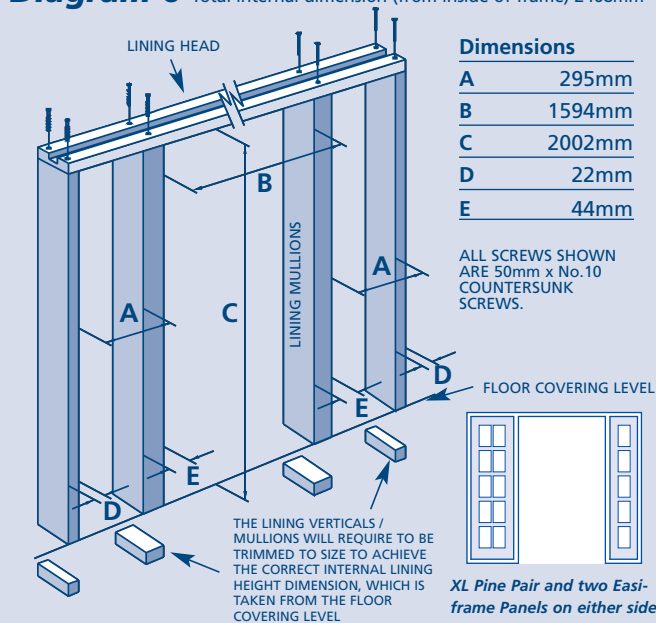

Diagram 6 Total internal dimension (from inside of frame) 2468mm



Fitting the Lining (all projects)

Once assembled the lining should be moved into the required position in the opening. Check the lining is square by checking the diagonal dimensions are equal and that the lining is vertical from back to front. The head should be horizontal and that the frames internal dimensions are as in the appropriate diagram.

Secure the lining in place using suitable fixings (not supplied). Ensure at least 6 fixings per upright and 4 for the head piece. Ensure you space the fixings equally along the length.

Make sure that the lining remains vertical and square after fixing, take care to ensure that the internal dimensions are maintained. Pack between the linings and opening to maintain the correct dimensions if necessary.

If the bottom rails have been fitted, two fixings are required at each rail, securing these to the floor. **Diagram 7**

If the bottom rails have not been fitted, the lining Mullion is secured to the floor by skew screwing through the mullion in to the floor **Diagram 7**

Hanging the Door Pair and Panel

Hinges and Hanging the Door Pair

Cut housings for hinges in each of the doors with corresponding housings in the Lining Verticals and Mullions.

Ensure when hanging the door that there is a 2mm gap on each side of the door, a 2mm gap between the meeting stiles and a 2mm gap between the lining head and the top of the door and the floor surface and the bottom of the door.

Installing the Door stops

Glue and pin the door stops to the lining. Cut one end of the door stop length to the correct internal length ensuring that this end is cut with a mitre. **If you need to adjust the vertical length cut from the un-mitred end.** Position the stops when the doors are in the closed position.

Fitting the Easi-frame Side Panels or Demi Panels

Fixed Panel:

Pin and glue one side of each of the four Panel beads in position (**Diagram 8**) Use packing pieces in between the lining bottom rails to ensure that the Panel lines up with the Door Pair. Run silicon (in a line) around one side of the fitted panel bead to eliminate any rattle in the fitted Panel.

Insert the Panel into the lining. To hold the Panel in position, Pin and glue the other Panel bead into position (**Diagram 9**). Repeat for other panel

Hinged Panel:

The Panel should only be hinged off from the vertical lining.

Housings for the hinges should be cut into both the Panel and the lining vertical.

In hanging the Panel ensure that it lines up with the fitted Door Pair

The Panel bead can now be glued and pinned to the lining to act as the Panel stop. Position the beads when the Door Pair is closed. Repeat for other Panel

Note when a hinged panel is aligned to Bi-fold doors (see hanging a Bi-fold) there will be a 10mm gap between the top of the hinged panel and the head lining. Pin and Glue the length of lining infill to cover this gap (diagram 9b)

Diagram 7

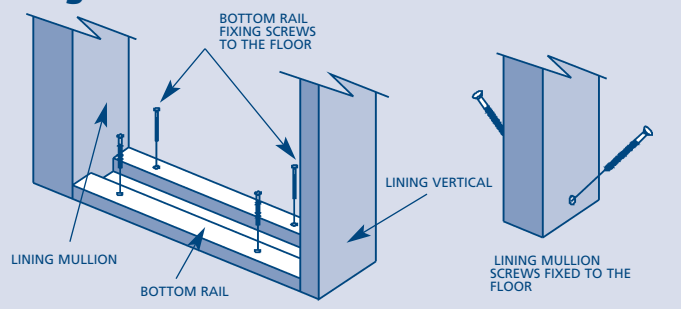

Diagram 8

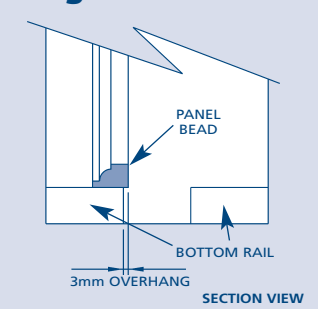

Diagram 9

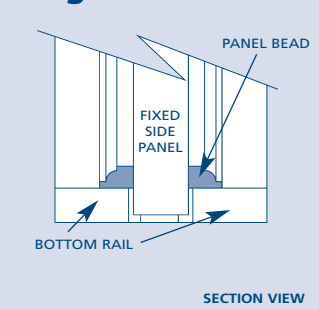

Diagram 9b

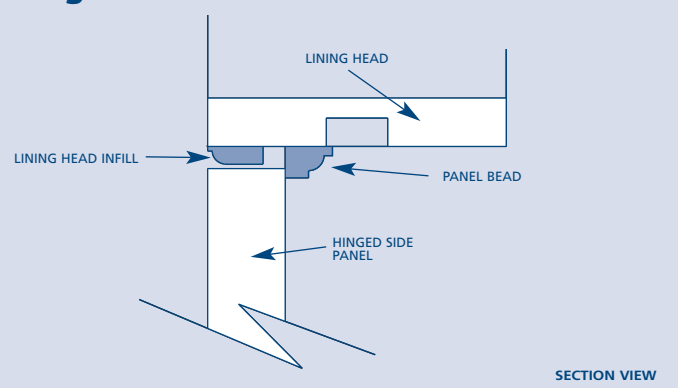
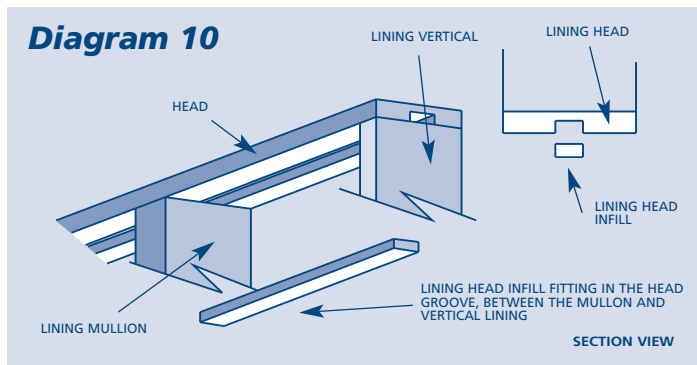

Diagram 10

Hanging the Bi-fold and Panel

The Bi-fold Track.

What you need to know before you start to fit the Bi-fold track system:

You must use the Easi-Frame Bi-fold pack This is available from the retailer where you purchased your Easi-frame Panel, Demi Panel or frame.

Identify the contents of the track pack from the contents list in the Easi-Frame Bi-fold Track pack. **Do not follow the fitting instructions contained in the track pack.**

Remove one of the top pivot brackets from the track

Identify the Lining Head Infill components. These components need to be cut to length, glued and pinned into the lining groove of the side panel opening. **(Diagram 10)**

Fitting the Bi-fold track

Cut the length of the track to the internal width of the bi-fold opening. Screw the track into the groove in the lining head. The end of the bi-fold track with the fitted top pivot bracket must be matched with the fixed panel side.

Fit the Bi-fold Pivots to each panel in the position shown in **Diagram 11**. Use an 11mm Drill Bit. **The holes must be at least 38mm deep.** Note that the panel that is fixed to the vertical lining (the fixed panel) requires two pivot holes (one at the top and one at the bottom) and the other panel (the Guide panel) requires just one hole at the top.

Tap the top and bottom pivots into place. The bottom pivots are adjustable, the top pivots are sprung loaded.

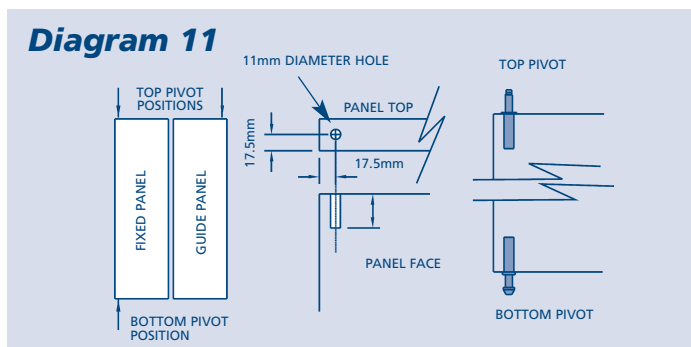
Diagram 11

Hinges

Fit the hinges between each Panel or Demi panel (The pre-assembled XL Joinery Bi-folds are already hinged together) Hinges should be fitted as in **Diagram 12** on page 6 and are designed to be concealed when the bi-fold is pulled shut.

Fit the Jamb bracket securely to the floor ensuring that the centre slot of bracket is in line with the hole in the top bracket of the track.

Screw fix the Jamb bracket to the lining vertical and the floor using the countersunk screws provided **(Diagram 13)** on page 6.

Fitting the Panels

The side of the assembled bi-fold that is fixed to the vertical lining is the 'Fixed panel', the side of the assembled bi-fold that is hinged to the fixed panel is the 'Guide panel'.

Attaching the assembled bi-fold

Snap the slide guide into place in the track.

Lift the assembled Bi-fold into position, inserting the top pivot of the fixed panel into the fixed pivot bracket in the track and then insert the corresponding bottom pivot into the Jamb bracket. n.b The top pivots are sprung loaded **(Diagram 13a)** on page 6.

Locate the top pivot of the guide panel in between the two springs in the slide guide **(Diagram 13b)** on page 6. Be aware that it is usual for tension to be maintained in these springs when the panels are in the shut position - this allows the panels to snap shut.

Adjust the height of the fixed panel so that the top of the panel is **10mm** lower than the bottom of the lining head. Achieve this by lifting the panel to the desired height and rotate the bottom pivot guide. Clockwise rotation will raise the panel, anti-clockwise rotation will lower the panel **(Diagram 14)** on page 6. **Do not attempt to turn the bottom pivot while it is still engaged in the Jamb Bracket.**

If required the fixed panel can be moved closer to or further from the Vertical Lining by readjusting the position of the top pivot bracket in the track and re-positioning the bottom pivot in the Jamb Bracket

Ensure that the Fixed Panel is plumb with the lining vertical and that both panels can shut without catching on the lining.

Installing the Head Panel stops

The Head Panel Stop is pre-cut to the correct dimensions. The Vertical Panel Stops will require trimming for the unmitred end.

With the assembled bi-fold closed locate the head panel stop into the correct position. Mark with a pencil the position of the head stop onto the far edge of each of the Guide Panels. **(Diagram 15)** on page 6. Remove the stop. On each of the Guide Panel edges cut a 10mm x 10mm chamfer down the edge of each Guide panel up to the pencil mark. (You may have to remove the assembled Bifold from the track to cut these chamfers).

The Head stop can now be glued and pinned into place. (again make sure that the assembled Bi-fold is closed when fixing the Head Stop **(Diagram 16)** on page 6.

Installing the Vertical Stops

Glue and pin the vertical lining stops into place, aligning them with the Head Stop **(Diagram 16)** on page 6.

Fitting the Panel Mullions

Glue and pin the Panel Mullions on to the edge of the Fixed Panel to hide the gap between the panels **(Diagram 17)** on page 6.

Bi-fold furniture

Fit the panel & Bi-fold furniture as required.

Architrave.

Due to the many different profiles of skirting available we do not supply an Architrave. Any softwood Architrave is suitable - ensure that you match the profile on your skirting when you purchase your architrave. Glue and pin the Architrave into position to cover the gap between the wall and the lining

THE ANSWER IS EASI-FRAME NOW WHAT'S THE PROJECT

