

# HARDWOOD STAIR CONVERSION SYSTEM

Convert your existing staircase to solid hardwood easily and cost effectively

Prior to installing any treads please read this warning note: You **MUST** use **ONLY** an MS-Polymer adhesive to fit this product. Do **NOT** use standard building adhesives as these do not provide the correct bonding required. MS Polymer adhesives are available from all good builders merchants.

## Step 5 – Installation & Finishing

Starting with the top two treads of the staircase, bond into place the rear most section of each tread, which you have previously trimmed to width and depth. With these in place, next bond on the riser panels for these two treads. (fig7).

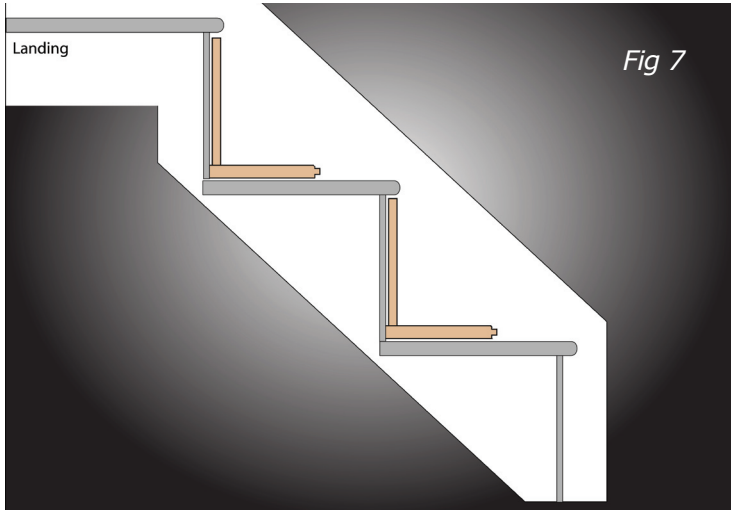

With these installed, you can now bond into place the front tread section, along with the riser moulding (Fig8). In this manner, continue to install treads, working downwards a tread at a time.

Winder and quarter space landing treads are installed in

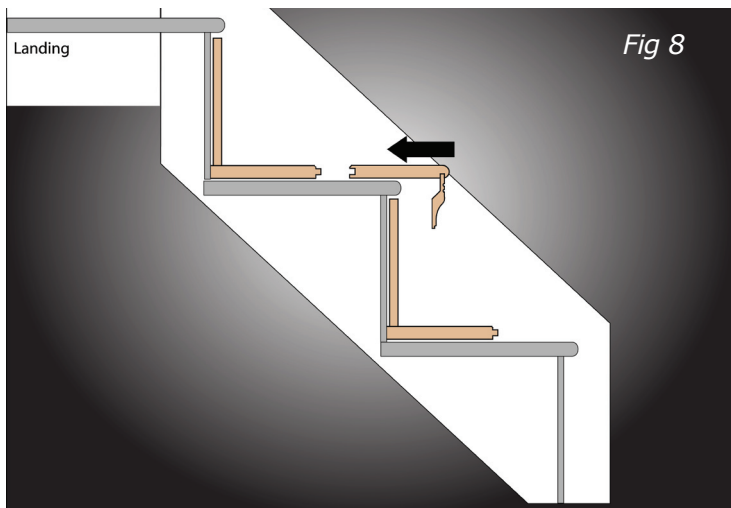

the same sequence. The finished staircase should be left for 24hrs for the glue to fully cure.

Your stair renovation kit is supplied unfinished to allow you to match to neighbouring flooring and balustrade. The system should be finished as soon as practical with a proprietary flooring finish to protect it from damage.



### Pack Contents:

Straight Step Pack (Contains tread, riser & riser moulding, (stairs up to 1000mm wide)

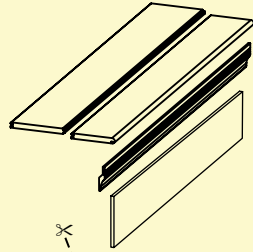

Winder Step Pack (Contains tread, riser, extension board & riser moulding, (1220mm wide)

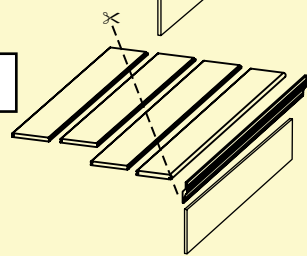

Tread Extension (to extend step pack for quarter landings, 1000mm)



20mm Flooring Nosing (1000mm)



Bullnose Riser Kit (1000mm)

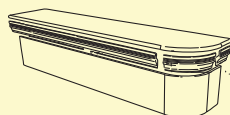
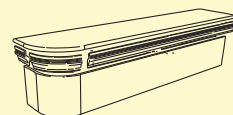

Ash



Walnut



Oak



# INSTALLATION INSTRUCTIONS

**Your Blueprint joinery Staircase Conversion System has been designed to be easy to install.**

No structural alterations to the stairs are required, simply trim your new treads and risers to size and bond into place over the old stairs. Please follow the instructions below carefully for a superb hardwood finish staircase. If you require any further advice on your installation, please contact our team on 01691 671020.

## Step 1 – Removal of Existing Coverings and Preparation.

Remove any existing stair coverings such as carpet. Make sure to remove any gripper rod and check that all nails or pins are removed or driven flush with the surface of the treads and risers. Your treads will need to be reasonably even and straight to ensure a good finish.

## Step 2 – Cutting Treads & Risers to Size

Carefully measure the width of your treads and cut the new tread and riser components to this width (Fig 1). Do not cut winder tread packs at this point.

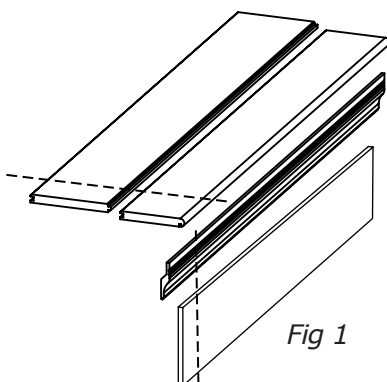

Next, trim the rear section of the new tread to fit the depth of your existing tread. The easiest way to do this is to place the new nosing onto the existing tread, ensuring that the groove for the riser moulding is positioned to the front of the existing nosing. Offer up the rear section of the tread, mark and cut (Fig 2).

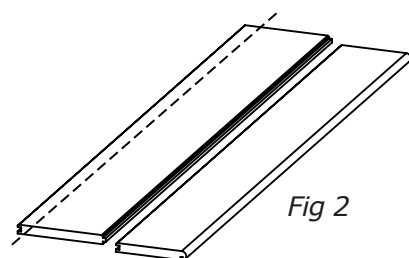

The new riser is now trimmed to height. Place a section of the new tread onto an existing tread and the riser on top. Mark and trim to height. The new riser should sit flush against the old riser, finishing underneath the existing bullnose.

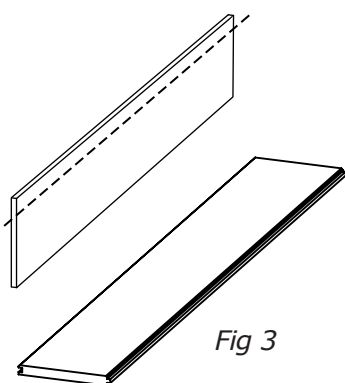

At this stage the treads and risers are ready to be installed.

## Step 3 – Quarter Space Landing & Winder Treads

Many stairs have either a quarter space landing or winder treads part way up the stairs.

For quarter space landings, you will need to add extension boards to the rear of a standard tread pack. A standard tread pack provides 284mm depth and each extension pack will add a further 142mm to the rear of the tread pack (Fig 4). As with a normal tread, cut the boards to width, and the rear most board to depth.

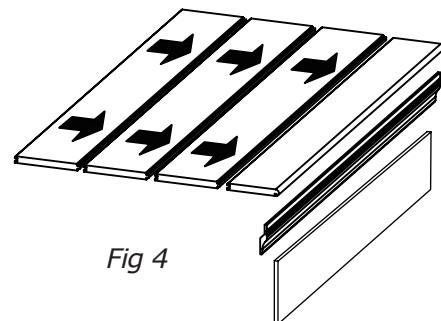

Winder tread packs are available for winder steps. These work in a similar way to the quarter space treads, with the finished tread cut at an angle to suit the winder step. You will need one winder tread pack for each winder tread (Fig 5). Note that these treads are wider than your standard treads and should be cut to suit.

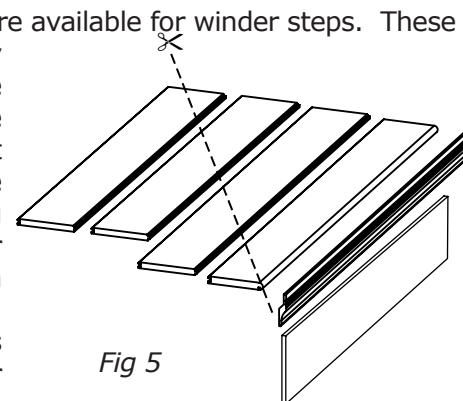

## Step 4 – Bullnose Treads

Some stairs will have a bullnose step to begin the staircase which can also be clad. You will need to purchase a bullnose tread kit in either left or right hand formats.

A right hand bullnose tread, has the curved side of the tread to the right hand side of the staircase when looking up from the bottom of the stairs. The diagram below shows a left hand bullnose tread pack (Fig 6).

To prepare your bullnose tread, first trial fit the the shaped riser section. This will need to be trimmed to width, depth and height.

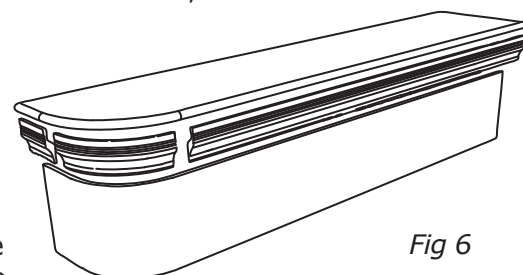

Next offer up the riser moulding to determine where the tread will sit. Trim the tread sections to width and the rear section to depth. The rear tread section will usually also need to be trimmed to fit around the newel post. Finally trim the straight riser moulding sections to length and your bull nose step is ready to install.